

LED Emergency Lighting Unit - 72W

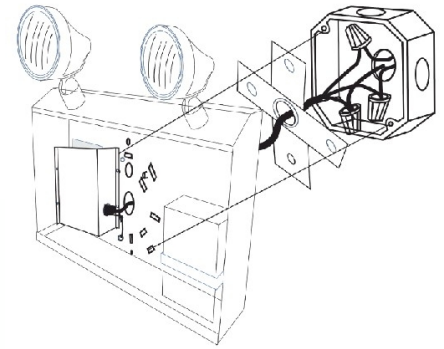

#1068 - BP-72W

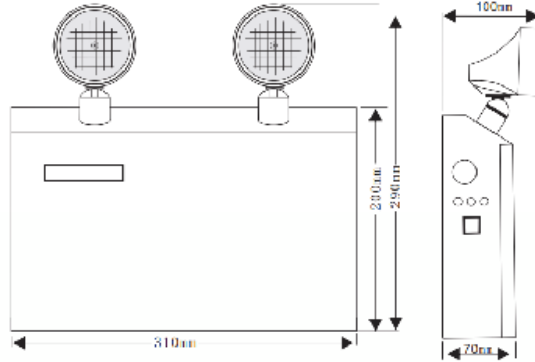

ELECTRICAL SPECS			
Input Voltage	100V-347VAC 50/60Hz	Battery Type	Lead-Acid
Output Voltage	12VDC	Battery Charge Time	24 hours
Indicator	Charge, Discharge, Test	Battery Discharge Time	@72W > 30 minutes
Battery Capacity	72W (12V x 7Ah)		@24W > 90 minutes
LIGHTING SPECS			
Lamp Type	LED	Lamp Power	2 x 2W (4W)
Lamp Input Voltage	6-12VDC	LED Lumen Output	260 lumens
Safety Certification	cCSAus	Safety Standards	CSA C22.2 No. 141-15 CAN/CSA-C22.2 No. 250.13-17
LED Head Size	2-5/8" Diameter	Environmental Rating	Damp Location
OTHER SPECS			
Housing Material	Powder Coated Steel Body Flame Retardant ABS Remote Head	Material Grade	UL 94V0
Housing Colour	White	Operating Temperature	0°C to 40°C / 32°F to 104°F
Dimension (inch/mm)	12.2" (W) x 7.87" (H) x 2.75" (D) 310mm (W) x 200mm (H) x 70mm (D)	Installation Method	Wall Mount, Pendant Mount
Weight	6.4 lbs / 2.9Kg	Warranty	5 Years